

*Innovative Power Engineering at its best!*

# HIGH VOLTAGE VACUUM CIRCUIT BREAKER

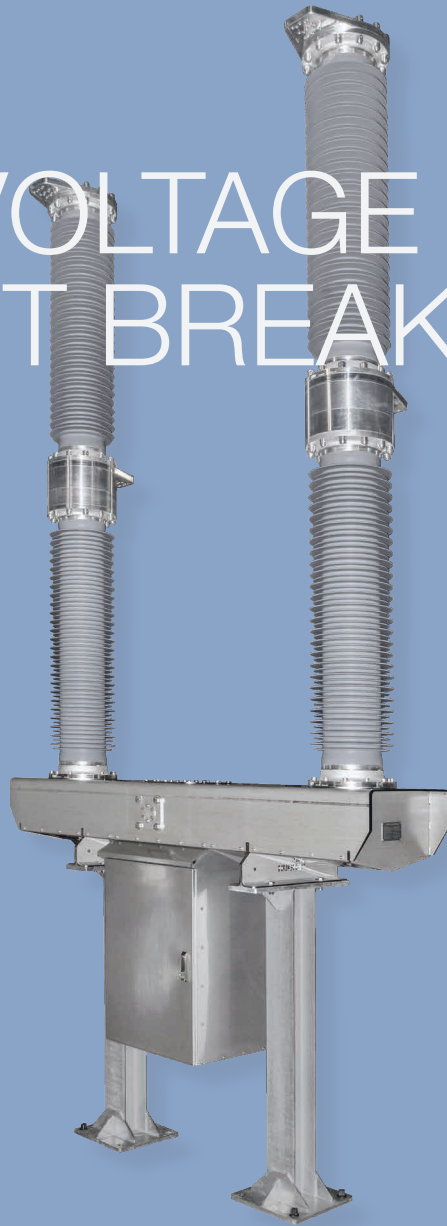

OVX1402 HIGH VOLTAGE, SOLID INSULATED  
VACUUM CIRCUIT BREAKER SERIES FOR  
RALWAY FEEDER STATIONS

- 145 kV, 2500 A, 31.5 kA, 16.7 Hz
- Solid insulated vacuum interrupter technology



# ABOUT US

Hughes Power System is a Swedish manufacturer of environmentally friendly equipment for electrification and automation of mass transport and electrical distribution systems. Very high quality standards together with innovative approach result in an advanced range of products, aiming to improve network quality by minimizing the number and duration of faults.

Our product portfolio includes:

- High voltage solid insulated vacuum circuit breakers
- Reclosers
- Disconnectors
- Motor drives for disconnectors
- Traction DC power supplies

With its more than 30 years expertise in research, development, manufacturing, marketing and sales the company operates in many countries though cooperation with local partners. As we move towards our goal of being a world class advanced technological company in electrical utility products, we guarantee our commitment to the well known Swedish standards of reliability, safety and quality.

The majority of Hughes Power System's products are designed and built in Sweden.



## GENERAL DESCRIPTION

### OVX1402

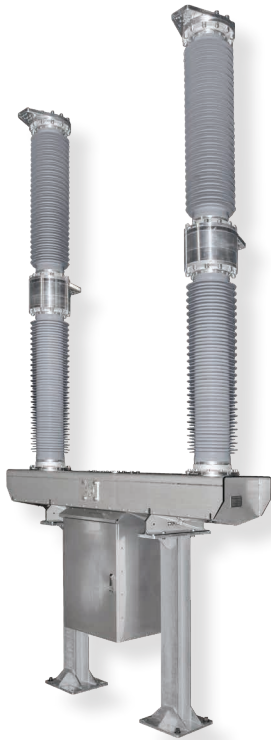

### WHAT IS AN OVX1402 HIGH VOLTAGE VACUUM CIRCUIT BREAKER

Hughes OVX1402 high voltage, solid insulated vacuum circuit breaker for 145kV is designed and manufactured in Sweden for different applications.

The product has extremely high mechanical endurance and outstanding electrical parameters with solid insulation and with high performance vacuum interrupters.

This combination provides highly reliable maintenance free products with low life cycle costs.

Gas free product, environmentally friendly.

### OVX1402 KEY FEATURES:

- Solid insulated;
- 145 kV 2-phase;
- 2500 A, 31.5 kA;
- 650 kV BIL;
- 275kV PF over open contact;
- Steel spring mechanical actuator;
- Solution for 2-phase systems;
- Vacuum interrupter enclosed in a solid insulation;
- Anti-vandalism poles fitted with polymeric insulators as standard;



Lower connection terminal with multiple cable shoe standard pattern

### OVX1402 ADVANTAGES:

- **Low maintenance.** Hughes vacuum circuit breakers are built to remain in operation for more than 30 years without major maintenance due to the highest quality materials used in its construction;
- **Solid insulated bushings** that exclude risk for SF6 or mix gas leakage and oil leakage;
- **High current vacuum interrupters** that will not produce any harmful switching products and are very easy to replace in comparison to gas insulated interrupters;
- The OVX1402 uses **high-level insulated** bushings with polymeric surface that gives superior BIL rating;
- The vacuum interrupter has **innovative design** allowing the unit to be modularized between 1, 2 or 3 poles for different applications. Normally 2 poles versions are used for railway electrification and 3 poles version is used for electrical transmission systems including renewable energy sectors;
- **Low life cycle cost** is guaranteed due to the combination of extremely high mechanical endurance and outstanding electrical parameters;
- The circuit breaker is **completely prewired** which makes it an easily remote-controlled solution;
- Both connection terminals can be supplied with **hole patterns** in accordance with ANSI or IEC standards.



OVX1402

## OPERATIONAL MECHANISM

### PANELS AND INTERNAL PARTS

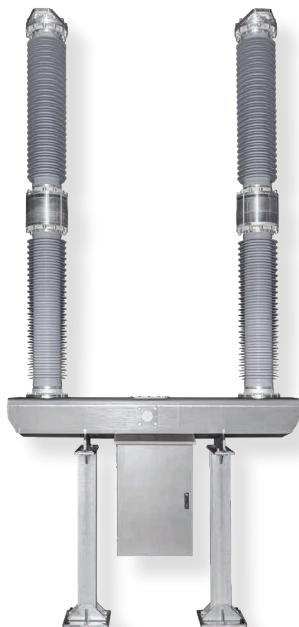

### MAIN PANEL (1) BUTTONS AND INDICATORS:

- Mechanical spring charge indicator (2) shows the status of the stored energy mechanism;
- Switch main mechanical position indicator (3):
  - Red - switch is closed;
  - green - switch is tripped;
- Button (4) is “door open indicator” to the SCADA system, “lamp On” function;
- Switch electrical operation and indicator panel (5);

## ELECTRICAL OPERATION AND INDICATOR PANEL (5):

- Rotary switch (5) is the Remote – Off – Local switch;
- Green button – indicator (6) operates the switch to Trip and indicates the switch position;
- Red button – indicator (7) operates the switch to Close and indicates the switch position;
- Operation buttons can be supplied with a safety delay timer from 10 - 120 second's;
- Blue indicator lamp (8), indicates that the spring operation mechanism is fully charged and ready for a momentary Trip – Close - Trip operation;



Electrical operation and indicator panel

## INTERNAL PARTS OF THE CABINET:

- The circuit breaker is completely prewired which makes it an easily remote-controlled solution;
- The electrical contact (10) has the prewired SCADA interface that provides information about the switch position and connects to multiple CAM switches and the heating element (11);
- Inside the spring operation mechanism is the mechanical operation counter (12), control electronics with its automatic fuses;

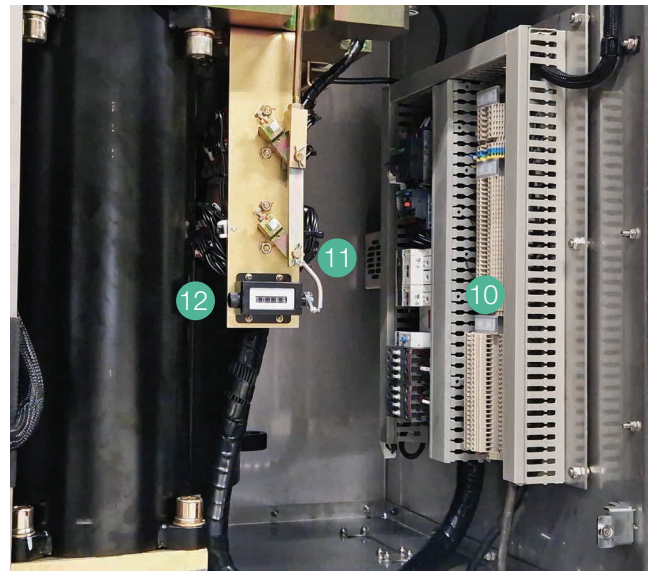

Internal parts of the spring mechanism cabinet

# MODULARIZED VACUUM CIRCUIT BREAKER

## COMPONENTS

### OVX1402 CONSISTS OF:

- Top solid insulated bushing (1) has upper connection terminal with low internal resistance;
- Thick metal connection terminal (2) that functions also as a heat sink for the vacuum interrupter bottle, that is installed inside the top bushing;
- The lower bushing (3) with the internal operating push-pull rod installed inside;
- The lower connection terminal (4) is a joint point for both bushings;
- The frame of the circuit breaker (5) contains the mandatory rating plate (6) with the electrical data in accordance with ANSI and IEC standards;

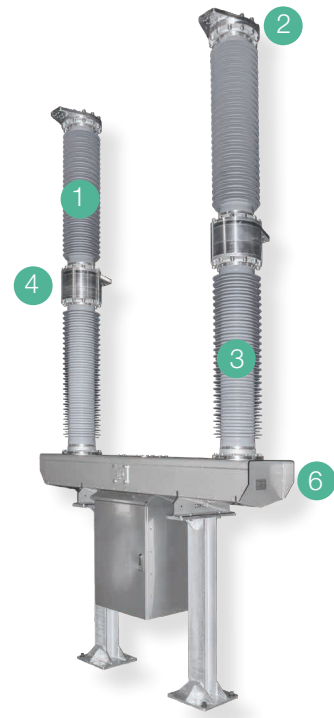

OVX1402 frame with rating plate

# TECHNICAL DATA

## OVX1402

TECHNICAL PARAMETER	OVX1402
Type	outdoor vacuum circuit breaker
Number of phases	2
Operation mechanism	high power steel springs mechanism
Insulators	Fiberglas + XLR silicone
Rated frequency, Hz	16.7
Maximum altitude, m	2000
Rated voltage, kV	145
Insulating medium of contacts	vacuum
Rated current conformed to the transformer capacity, A	2500
Rated power frequency withstand voltage (16.7 Hz/1 min) to earth/across open contact, kV	275
Lightning impulse withstand voltage (1.2/50 µs), earth/across open contacts, kV	650
Rated breaking current 3s, kA	31.5
Rated making current, kA	80
Closing time,including electrical circuit, ms	≤50
Opening-time, including electrical circuit, ms	≤21
Creep distance, mm/kV	25, 31, 48
Working sequence	C-0.3-OC-3min-OC
Coil operating voltage, V DC*	48, 60, 72, 110, 220
Motor operation voltage, V DC*	48, 60, 72, 110, 220
Rated power of motor, W	600
Number of closing coils	1 x
Power consumption of close coil, W	440
Number of trip coils	2/3 x*
Power consumption of trip coils, W	400
Number of normally open blocking contacts	12 x
Number of normally closed blocking contacts	12 x
Number of switching operations	10,000
Mechanical buttons for closing/opening located in the operating mechanism	Yes
Remote/local control switch(electrical)	Yes
Close open buttons with LED indicators in cabinet (electrical)	Yes
Size (HxLxW), mm	5740 x 2480 x 690 at 31 mm/ kV
Heater voltage	110 VDC, 230 VAC

\* High speed trip mechanism

# MODULARIZED VACUUM CIRCUIT BREAKER

## DRAWINGS

OVX1402

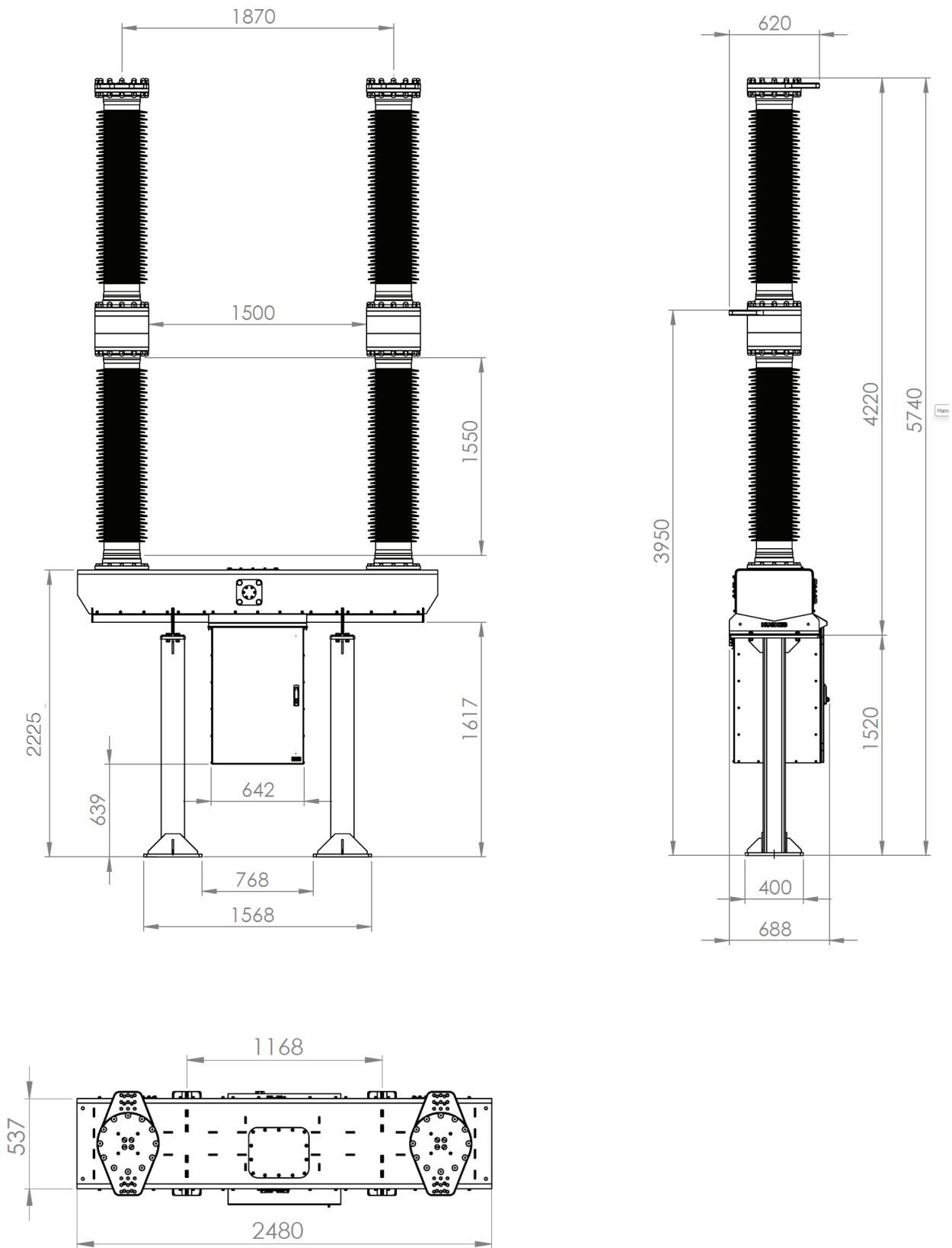

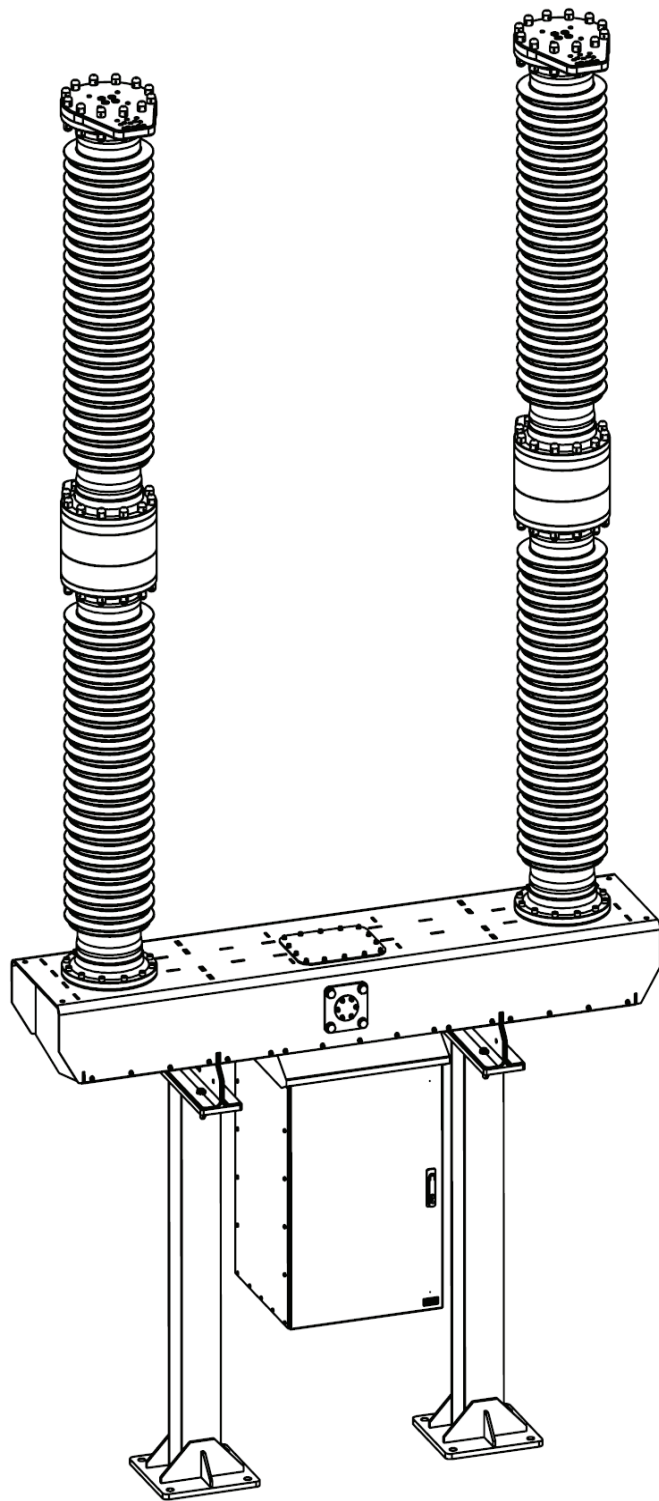



Hughes Power System is a Swedish manufacturer of environmentally friendly equipment for electrification and automation of mass transport and electrical distribution systems. Very high quality standards together with innovative approach result in an advanced range of products, aiming to improve network quality by minimizing the number and duration of faults.

The majority of Hughes Power System's products are designed and built in Sweden.

[www.hughespowersystem.com](http://www.hughespowersystem.com)

